

## MATERIAL

Aluminium, matte finish.

## STANDARD EXECUTIONS

Back mounting, threaded blind holes:

- **GN 428-AL-A-EL:** anodised aluminium, natural colour.
- **GN 428-AL-A-SR:** epoxy resin coating, RAL 9006 grey colour.
- **GN 428-AL-A-SW:** epoxy resin coating, RAL 9005 black colour.

Front mounting by means of AISI 304 stainless steel screws, nuts and washers, included in the supply:

- **GN 428-AL-B-EL:** anodised aluminium, natural colour.
- **GN 428-AL-B-SR:** epoxy resin coating, RAL 9006 grey colour.
- **GN 428-AL-B-SW:** epoxy resin coating, RAL 9005 black colour.

## FEATURES AND APPLICATIONS

GN 428 handles are made with a folded aluminium profile and have excellent stability and an ergonomic design.

These handles are typically used on turning or rolling doors for machines and equipment.

## SPECIAL EXECUTIONS ON REQUEST

- Different lengths.
- Different finishes.



GN 428-AL-A

GN 428-AL-B

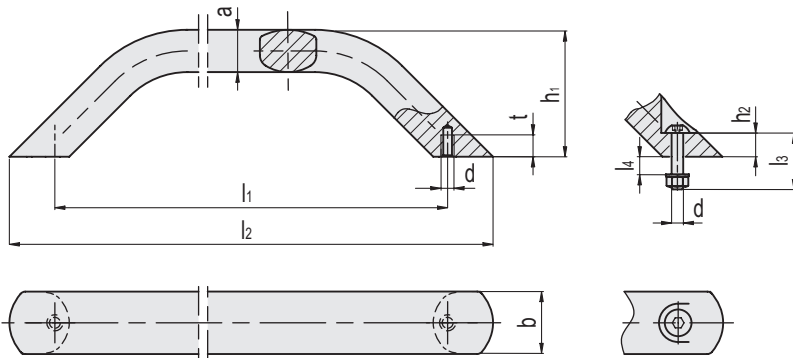

Conversion Table	
1 mm = 0.039 inch	
l1	
mm	inch
200	7.87
250	9.84
300	11.81
400	15.75

## GN 428-A

METRIC

Code	Description	b	l1	l2	d	a	h1	t	⚖
GN.41901	GN 428-AL-28-200-A-EL	28	200	240	M8	18	63	10	340
GN.41902	GN 428-AL-28-200-A-SR	28	200	240	M8	18	63	10	340
GN.41903	GN 428-AL-28-200-A-SW	28	200	240	M8	18	63	10	280
GN.41911	GN 428-AL-28-250-A-EL	28	250	290	M8	18	63	10	336
GN.41912	GN 428-AL-28-250-A-SR	28	250	290	M8	18	63	10	340
GN.41913	GN 428-AL-28-250-A-SW	28	250	290	M8	18	63	10	340
GN.41921	GN 428-AL-28-300-A-EL	28	300	340	M8	18	63	10	389
GN.41922	GN 428-AL-28-300-A-SR	28	300	340	M8	18	63	10	391
GN.41923	GN 428-AL-28-300-A-SW	28	300	340	M8	18	63	10	391
GN.41931	GN 428-AL-28-400-A-EL	28	400	440	M8	18	63	10	499
GN.41932	GN 428-AL-28-400-A-SR	28	400	440	M8	18	63	10	505
GN.41933	GN 428-AL-28-400-A-SW	28	400	440	M8	18	63	10	490

## Conversion Table

1 mm = 0.039 inch

1	
mm	inch
200	7.87
250	9.84
300	11.81
400	15.75
500	19.69
600	23.62
800	31.50

## GN 428-A

METRIC

Code	Description	b	l1	l2	d	a	h1	t	⚖
GN.41941	GN 428-AL-36-300-A-EL	36	300	355	M10	26	71	14	740
GN.41942	GN 428-AL-36-300-A-SR	36	300	355	M10	26	71	14	740
GN.41943	GN 428-AL-36-300-A-SW	36	300	355	M10	26	71	14	800
GN.41951	GN 428-AL-36-400-A-EL	36	400	455	M10	26	71	14	934
GN.41952	GN 428-AL-36-400-A-SR	36	400	455	M10	26	71	14	948
GN.41953	GN 428-AL-36-400-A-SW	36	400	455	M10	26	71	14	948
GN.41961	GN 428-AL-36-500-A-EL	36	500	555	M10	26	71	14	1155
GN.41962	GN 428-AL-36-500-A-SR	36	500	555	M10	26	71	14	1160
GN.41963	GN 428-AL-36-500-A-SW	36	500	555	M10	26	71	14	1160
GN.41971	GN 428-AL-36-600-A-EL	36	600	655	M10	26	71	14	1353
GN.41972	GN 428-AL-36-600-A-SR	36	600	655	M10	26	71	14	1410
GN.41973	GN 428-AL-36-600-A-SW	36	600	655	M10	26	71	14	1300
GN.41981	GN 428-AL-36-800-A-EL	36	800	855	M10	26	71	14	1750
GN.41982	GN 428-AL-36-800-A-SR	36	800	855	M10	26	71	14	1882
GN.41983	GN 428-AL-36-800-A-SW	36	800	855	M10	26	71	14	1780

## GN 428-B

METRIC

Code	Description	b	l1	l2	l3	d	a	h1	h2	l4	⚖
GN.41906	GN 428-AL-28-200-B-EL	28	200	240	30	M8	18	63	11.8	10	340
GN.41907	GN 428-AL-28-200-B-SR	28	200	240	30	M8	18	63	11.8	10	340
GN.41908	GN 428-AL-28-200-B-SW	28	200	240	30	M8	18	63	11.8	10	340
GN.41916	GN 428-AL-28-250-B-EL	28	250	290	30	M8	18	63	11.8	10	363
GN.41917	GN 428-AL-28-250-B-SR	28	250	290	30	M8	18	63	11.8	10	369
GN.41918	GN 428-AL-28-250-B-SW	28	250	290	30	M8	18	63	11.8	10	369
GN.41926	GN 428-AL-28-300-B-EL	28	300	340	30	M8	18	63	11.8	10	417
GN.41927	GN 428-AL-28-300-B-SR	28	300	340	30	M8	18	63	11.8	10	425
GN.41928	GN 428-AL-28-300-B-SW	28	300	340	30	M8	18	63	11.8	10	425
GN.41936	GN 428-AL-28-400-B-EL	28	400	440	30	M8	18	63	11.8	10	528
GN.41937	GN 428-AL-28-400-B-SR	28	400	440	30	M8	18	63	11.8	10	535
GN.41938	GN 428-AL-28-400-B-SW	28	400	440	30	M8	18	63	11.8	10	535
GN.41946	GN 428-AL-36-300-B-EL	36	300	355	40	M10	26	71	16.6	13	750
GN.41947	GN 428-AL-36-300-B-SR	36	300	355	40	M10	26	71	16.6	13	774
GN.41948	GN 428-AL-36-300-B-SW	36	300	355	40	M10	26	71	16.6	13	774
GN.41956	GN 428-AL-36-400-B-EL	36	400	455	40	M10	26	71	16.6	13	1000
GN.41957	GN 428-AL-36-400-B-SR	36	400	455	40	M10	26	71	16.6	13	1000
GN.41958	GN 428-AL-36-400-B-SW	36	400	455	40	M10	26	71	16.6	13	1000
GN.41966	GN 428-AL-36-500-B-EL	36	500	555	40	M10	26	71	16.6	13	1205
GN.41967	GN 428-AL-36-500-B-SR	36	500	555	40	M10	26	71	16.6	13	1250
GN.41968	GN 428-AL-36-500-B-SW	36	500	555	40	M10	26	71	16.6	13	1250
GN.41976	GN 428-AL-36-600-B-EL	36	600	655	40	M10	26	71	16.6	13	1400
GN.41977	GN 428-AL-36-600-B-SR	36	600	655	40	M10	26	71	16.6	13	1500
GN.41978	GN 428-AL-36-600-B-SW	36	600	655	40	M10	26	71	16.6	13	1500
GN.41986	GN 428-AL-36-800-B-EL	36	800	855	40	M10	26	71	16.6	13	1814
GN.41987	GN 428-AL-36-800-B-SR	36	800	855	40	M10	26	71	16.6	13	1820
GN.41988	GN 428-AL-36-800-B-SW	36	800	855	40	M10	26	71	16.6	13	1820